

DIN 382

STANDARD HSS
code 225 XXX

Závitové kruhové čelisti šestihřanné Hexagon die nuts Sechskant - Schneidmuttern Плашки шестиугольные

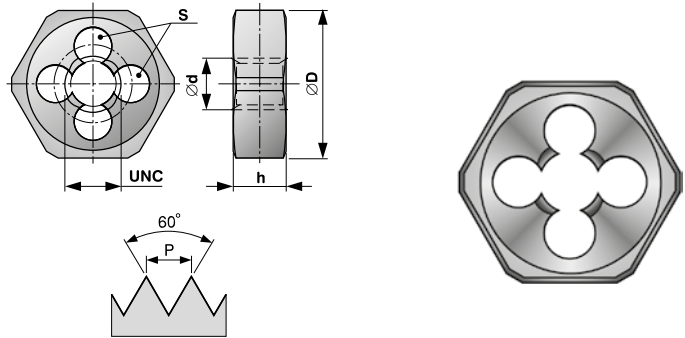

UNC
Unifikovaný hrubý závit ASME B1.1
Unified coarse thread ASME B1.1
Unifiziertes-Grobgewinde ASME B1.1
Унифицированная чёрная резьба ASME B1.1

Lícování: 2A / Tolerance: 2A /
Toleranz: 2A / Подгонка: 2A



1,5P

	z/1"	P	ØD	h	S		code
UNC 1/4	20	1,270	18	7	4	6,22	225 140
UNC 5/16	18	1,411	21	9	4	7,80	225 516
UNC 3/8	16	1,588	27	11	4	9,37	225 380
UNC 7/16	14	1,814	27	11	5	10,95	225 716
UNC 1/2	13	1,954	36	14	5	12,52	225 120
UNC 9/16	12	2,117	36	14	5	14,10	225 916
UNC 5/8	11	2,309	41	18	5	15,68	225 580
UNC 3/4	10	2,540	41	18	6	18,84	225 340
UNC 7/8	9	2,822	50	22	5	22,00	225 780
UNC 1	8	3,175	60	22	6	25,16	225 100
UNC 1 1/8	7	3,629	60	25	6	28,31	225 118
UNC 1 1/4	7	3,629	60	25	7	31,49	225 114
UNC 1 3/8	6	4,233	70	25	9	34,63	225 138
UNC 1 1/2	6	4,233	85	30	8	37,81	225 112
UNC 1 3/4	5	5,080	85	36	8	44,12	225 134
UNC 2	4,5	5,644	85	36	9	50,45	225 200



BUČOVICE TOOLS a.s.

*Materiál: HSS
Provedení: závit lapovaný
do UNC 1"
Závit: pravý*

*Material: HSS
Execution: lapped thread
to UNC 1"
Thread: right-hand*

*Werkstoff: HSS
Ausführung: geläpptes Ge-
winde bis UNC 1"
Gewinde: rechts*

*Material: HSS
Изготовлено: резьба
шлифованная до UNC 1"
Резьба: правая*